



D-2 INCORPORATED

Jet Fuel 1A High Pressure Conductivity Sensor

Installation & Safe Use Manual

**REVISION -
P/N A443-005**

This manual covers the installation and use aspects of the D-2 JF-1A-HP-HP Conductivity Sensor. D-2 continuously strives to meet the full expectations of our customers and we welcome comments on the structure, content and the ability of this manual to answer your questions regarding our product. If you have any suggestions or comments please contact us at Mail@D-2inc.com.

Read the instructions in this manual carefully before installing or starting the system. D-2 Incorporated will accept no liability for damages due to non-observance of this manual.



If the instructions in the operating manual are not adhered to or are inadequately adhered to, there shall be no entitlement to services under the warranty and the CE Declaration of Conformity shall cease to be valid.



Information in this manual is subject to change without notice and does not represent a commitment on the part of D-2 Incorporated.

No part of this manual may be reproduced or transmitted in any form or by any means, electronic or mechanical, without the prior written permission of D-2 Incorporated.

Where manuals are written in several languages, the text it was created in is considered the original.

D-2 Incorporated

19 Commerce Park Road
Pocasset, MA USA 02559

Phone: 01 508-329-2046

Telefax: 01 508-536-5206

E-Mail: Mail@D-2Inc.com

Internet: <http://www.D-2Inc.com>

© Copyright 2005, D-2 Incorporated, Pocasset, MA, USA

Notes for User



WARNING!

There is a danger to life and limb or a risk of serious injury if the notes on safety are disregarded!



CAUTION!

There is a risk of injury and damage to property if the notes on safety are disregarded!



ATTENTION!

There is a risk of damage to property if the notes on safety are disregarded!



IMPORTANT!

Notes on working procedures.

Revision History:

Rev	Date	Description	
-	11/08/07	Written	AJF

TABLE OF CONTENTS

OPERATION MANUAL

1.0 GENERAL & LABELING	5
2.0 INSTRUCTION FOR SAFE USE	6
3.0 SENSOR MAJOR COMPONENT IDENTIFICATION	8
4.0 SENSOR INSTALLATION (ASSEMBLING/DISMATLING)	9
5.0 SENSOR REMOVAL	20
6.0 SPECIFICATIONS & MAXIMUM ALLOWABLE VALUES	22
7.0 MAINTENANCE	24
8.0 ADJUSTMENT	25
9.0 DETAILS TO ALLOW SAFE USE AS INTENDED	25
10.0 SPECIAL CONDITIONS OF USE	25
11.0 OPTIONAL 4-20 TEMPERATURE OUTPUT	26

1.0 GENERAL & LABELING

JF-1A-HP Applications

The JF-1A-HP Conductivity Sensor is a 2-Wire 4-20 mA Electrical Conductivity Measurement Sensor.

Liquid media The sensor is used for measuring the electrical conductivity of liquid media:
In hazardous locations, Zone I of Explosion Group II C corresponding to EN guidelines

In hazardous locations Class I, Div. 1, Group B, C and D in accordance with FM and CSA guidelines



ATTENTION! *The sensor is not designed to meter gaseous media or solids.*

Manufacturer **D-2 Incorporated
19 Commerce Park Road
Pocasset, MA 02559, USA**

Type **II 2G**

Code



EEx d [ia] IIC T4

Testing Station **KEMA QUALITY, B.V., Utrechtseweg 310, 6812 AR Arnhem**

Certificate # **KEMA05ATEX1252**

Ambient Temp Range **-20 to 50 Celcius**

Process Max Temperature **40 Celcius**

Ambient Max Pressure **100 Bar (1450 PSIG)**

Maximum Voltage (Loop) **38 VDC**

Maximum Current (Loop) **22 mA**

Maximum (RS-232 Input) **(RXD) Maximum +/- 25 VDC +/- 5 mA**

Maximum (RS-232 Output) **(TXD) Maximum +/- 5VDC +/- 30 mA (Short Circuited)**

Test Voltage **Um = 250 VAC**

2.0 INSTRUCTION FOR SAFE USE

The D-2 JF-1A-HP Conductivity Meter reads conductivity in picosiemens/meter, fuel temperature in ITS-90 degrees C, and fully compensated Conductivity in picosiemens/meter per ASTM D 2624, Appendix X2 in liquid fuels and solvents. The sensor can be used in a 2 wire 4-20 mA industrial control loop or in conjunction with a serial input device using RS-232 IEEE Standard ASCII Serial Input Data. Optionally a 2 wire (4-20 mA) temperature interface can be added to allow remote monitoring of fuel temperature.



WARNING: Immediately switch off the sensor in the case of emergency!

Until the sensor is fully installed in a filled product line do not energize sensor.

When using the sensor to measure combustible media, observe the regulations concerning transport and storage of combustible liquids.

Observe applicable national regulations for installation abroad.

Only Ex d approved cable entry devices (e.g. cable gland) shall be used, with the apparatus.

Sensor is intended for use in product lines where the absolute maximum physical conditions do not exceed the specifications listed in Section 6.0.



CAUTION:

Sensors must be accessible at all times to facilitate operation and maintenance. Do not obstruct or block clear access.

Only specially trained and authorized persons are permitted to maintain and repair JF-1A-HP Sensors and their peripheral equipment.

Always depressurize the liquid end first before carrying out any work on the Sensor.

If hazardous or unknown sensor media are used, discharge and flush the liquid end before carrying out any work on the sensor.

Observe the safety data sheets of the measured liquids.

Always wear protective clothing (goggles, gloves) when handling hazardous or unknown liquids! This applies in particular to working on the liquid end.

Assembly of the JF-1A-HP Sensor with parts not tested and approved by D-2 Incorporated is prohibited and can result in damage to persons and property, for which no liability will be accepted.

Caution: Installation and Removal of the sensor from pressurized lines care MUST be taken to ensure sensor does not "fly" back to stop.

Caution: At no time should the main sensor body (electronic housing) be rotated in a continuous counter clockwise direction as sensor components may become undone resulting in liquid (product) ingress into sensor.

3.0 SENSOR MAJOR COMPONENT IDENTIFICATION

Figure 1
Major System Components

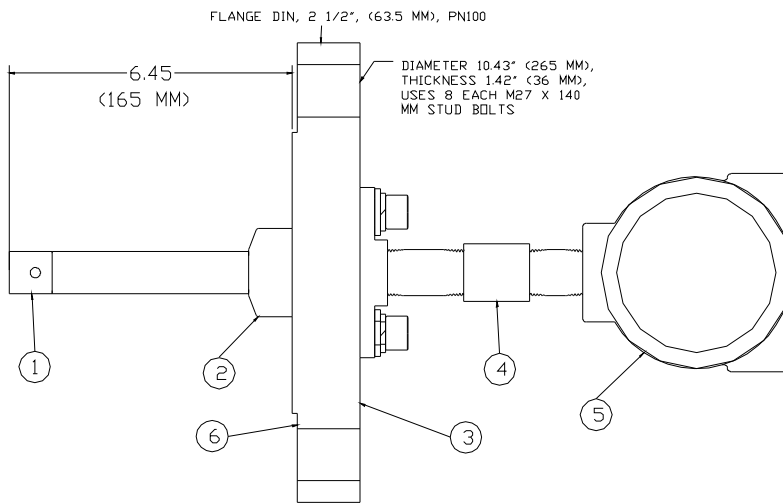

- 1 Sensor Active Tip
- 2 Sensor Isolator
- 3 Mounting Flange

- 4 Safety Sealing Header
- 5 Electronics Housing
- 6 Installation Reference Plane

4.0 INSTALLATION ASSEMBLING/DISMATLING

4.1 MECHANICAL INSTALLATION



WARNING!

Prior to Installation, local codes and regulations regarding the installation and operation of this type of device should be reviewed and strictly adhered with to ensure safe and reliable operation of the system.



WARNING!

Installation in Product Lines with Flow Above 1.5 M/sec (5 ft/sec) must observe recommendations as listed in Section 6.5



WARNING!

WARNING: Local Procedures to reduce the potential for electrostatic discharge should be observed prior to handling the JF-1 Sensor. Ensure service personnel have proper grounding equipment.

4.2 PIPE CONNECTIONS

D-2 requires a permanently installed on DIN 2 ½" PN100 flange. The face surface of flange and the distance to the product line must comply with the Figure 2:

4.4 INSTALLATION

1. Bolt DIN Provided flange to product line flange using bolts, washers, nuts, and, gasket which are in compliance with local codes. Torque all bolts per local code requirements.



ATTENTION! *Pushing the sensor to far into the main product line may result in damage to sensor and require factory re-calibration or repair. Ensure entry into main product line is clear and free of obstructions prior to installation of sensor onto flange.*



IMPORTANT! *Under high flow conditions, flow > 1.5 M/sec (5 ft/sec) installation depth should be verified as outlined in section 6.5 to prevent vortex flow separation inside critical sensor measurement volumes.*



IMPORTANT: *The Sensor should be mounted well away from possible sources of electromagnetic noise, such as large pump motors, AC power Lines, or electrical circuits containing large transient switching currents.*



WARNING: *Prior to arc welding in proximity to the JF-1A-HP sensor (closer than 10 meters (30 feet) the sensor should be either removed from the product line or at a minimum disconnected from all electrical connections to the sensor.*

4.5 High Flow Rate Installation

To reduce the instance of fluid flow separation inside the JF-1A-HP sensor assembly the tip of the sensor should intrude no more than 0.25" (1 CM) into the product flow. Insertion depth can be reduced by adding spacers under the flange. Spacers must meet local code regulations. D-2 defines high flow product lines as lines in which the velocity of product exceeds 1.5M/sec (5 ft/sec). Velocity can be determine by dividing the cross sectional area of your pipe $((I.D./2)^2 * 3.14$ dived into your product flow rate (in equivalent units of measure).

4.6 ELECTRICAL INSTALLATION



WARNING: Only Ex d approved cable entry devices (e.g. cable gland) shall be used, with the apparatus.



WARNING: All unused $\frac{3}{4}$ " NPT housing openings must be closed using EN50018 approved plugs.



WARNING: For the purpose of intrinsic safety the housing must be tied to earth. Safety Ground wire must be installed under housing ground screw in user wiring compartment. A cable lug shall be used and the conductor shall be mounted so that it is secured against loosening and twisting and that the contact pressure is permanently maintained. Note: the connections to earth located on the terminal blocks can not be used for this earth connection.

Electrical connection details are shown in Figure 3. There are 2 screw terminal blocks, the terminal block with 4 positions has the 4-wire interface, the terminal block with 3 positions services the 2-Wire Interface. These are "snap" out Molex screw terminals which can be removed to assist in wiring. Cabling used should be in compliance with the JF-1A-HP ATEX examination certificate. The 4-Wire defined as Power Ground RS-232C Transmit and Receive Data, the 2-Wire interface defined as 4-20 mA current loop and earth safety ground connections. Note the 4-Wire input power is polarity protected while the 2-Wire Input Power input is polarity insensitive; either terminal can be connected to the positive output of the power source.

Figure 3
2-WIRE ELECTRICAL CONNECTION DETAIL

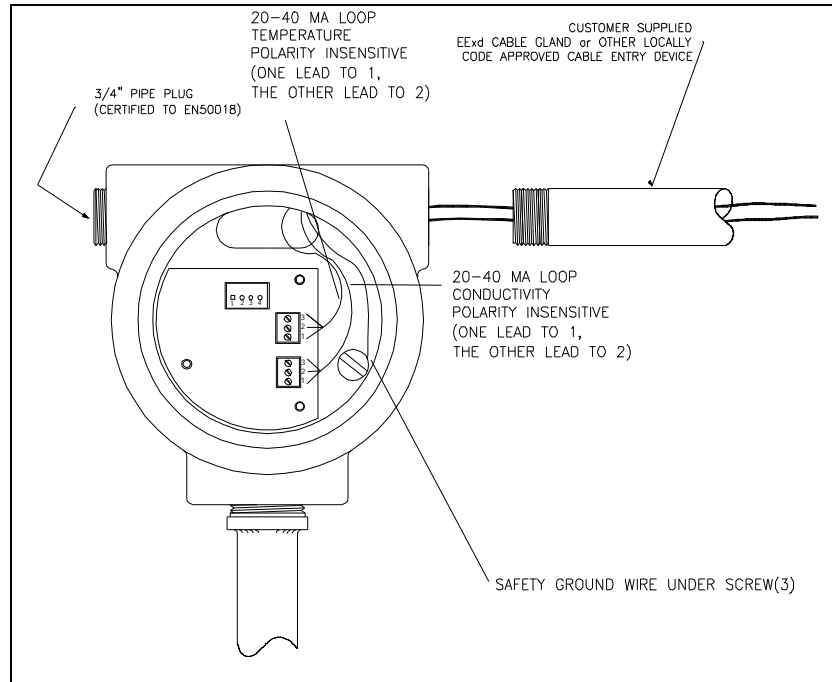

4.7 2-Wire 4-20mA LOOP CONSIDERATIONS



WARNING: 2-Wire Loop Maximum Resistance including wire can not exceed 500 ohms, or internal intrinsic over voltage safety devices in the JF-1A-HP sensor may be activated.

The 4-20 mA Loop supply open circuit voltage must be consistent with the "Open Circuit Supply" needs of the JF-1A-HP at both its minimum and maximum indicating currents. The JF-1A-HP has both input voltage limiting protection and polarity protection. These protection devices affect user supply voltage requirements. If proper loop supply voltage is not maintained, errors in indicated conductivity current may occur. The 4-20 mA loop supply voltage should comply with specifications section of the manual.

The maximum loop power supply voltage, under all conditions, must also

prevent the voltage across the sensor loop terminals from exceeding the maximum voltage listed in the specifications section of the manual. If this condition is not maintained, errors in the current output may occur.

D-2 recommends that a 24 VDC isolated supply be used to power the instrumentation loop. The supply should have high isolation (>500 Mohm). The current loop should be wired using shielded twisted pair wire. The shield should be single point grounded to a solid earth/safety ground.



ATTENTION: *Sensor wiring should be performed as required by local codes as they apply.*

4.8 RS-232 CONNECTIONS Considerations (4-Wire)

Figure 4
4-WIRE ELECTRICAL CONNECTION DETAIL

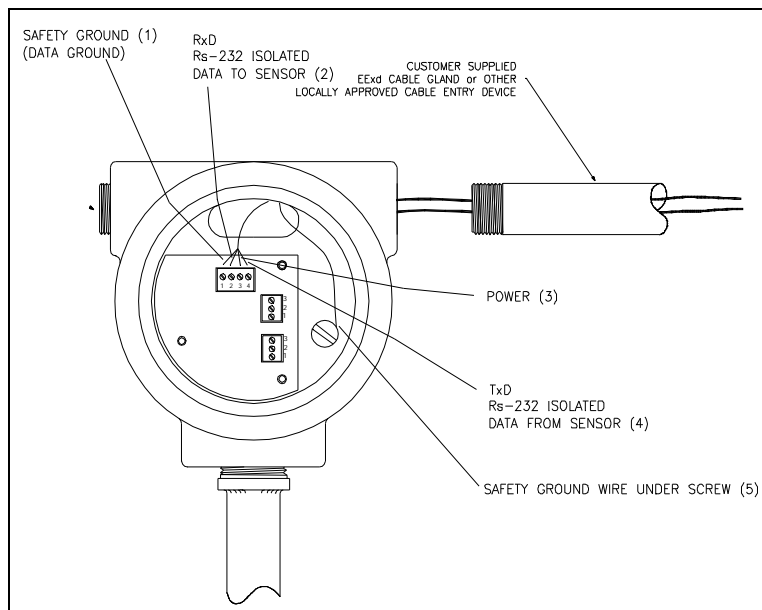

WARNING: *For the purpose of intrinsic safety the housing must be tied to earth. Safety Ground wire must be installed under housing ground screw in*

user wiring compartment. A cable lug shall be used and the conductor shall be mounted so that it is secured against loosening and twisting and that the contact pressure is permanently maintained. Note: the connections to earth located on the terminal blocks can not be used for this earth connection.

The 4 Terminal Screw Connector has both Power Input and RS-232/RS-485 Connections as listed in Table 1 below:

TABLE 1
SCREW TERMINAL CONNECTION PIN DETAIL

TERMINAL	Function
1	Data/Power Ground
2	RS-232 Data In (RXD)
3	Power Input +
4	RS-232 Data Out (TXD)

The RS-232 Interface is fully isolated from the sensor electronics through the use of optical isolators located in the JF-1A-HP/ATEX sensor.

Data cable for the RS-232 should be low capacitance data cable. Lengths in excess of 20 meters may result data degradation of the RS-232 signals.

4.9 Power Input (4-Wire)



WARNING: *Power supply must be fully isolated and meet all local and site codes for its use.*

Power input to the 4-Wire power connections should be clean filtered DC voltage in the range of 7 – 35 VDC. Current consumption is approximately 10 mA.

5.0 SENSOR REMOVAL



WARNING: *Power must be disconnected before sensor removal.*

5.1 DISCONNECT POWER

Turn off system power to the unit and disconnect electrical connections from the user interface. Remove any conduit connections from the JF-1A-HP Sensor. Ground the sensor to the main line prior to removal from the line.



WARNING: *Prior to handling sensor ensure operator is properly grounded to prevent possible electrostatic discharge.*



WARNING: *Ensure product line pressure is below 15 psia (1 Bar) prior to loosening ANY flange bolts.*

Remove the flange bolts and withdraw the sensor from the product line.

6.0 SPECIFICATIONS

The electrical parameters are factory calibrated to 1% of reading. However, due to fuel measurement characteristics, the repeatability and reproducibility limits are as follows:

Table 2
SENSOR SPECIFICATIONS

SENSORS:

Parameter	Conductivity	Temperature
Range	0 – 500 pS/M	-5 – 50 C
Accuracy *	+/- 2 pS/M (+/- 2%) of Reading	+/- 0.5 C
Resolution	0.1 pS/M	0.1 C
Sensor Type	Coaxial Electrode	Platinum RTD
Calibration	Internal Zero & Scale	NIST ITS-90

- This is at temperatures +/- 10° C of 20° C for the compensated output data only.

Table 3
SYSTEM SPECIFICATIONS

ELEMENT	SPECIFICATION
Flow Range	0 – 7.0 M/s Max
Fuel Process Temperature	-20 – 40 C (T4)
Environmental Temperature	-20 to 60 C Operation -40 to 80 C Storage
Power 2-Wire Input	24 VDC Minimum 38 VDC Maximum
Power 4-Wire Input	7 VDC Minimum 38 VDC Maximum
Pressure	100 Bar (1450 PSIG) Maximum
Usage	Class 1, Division 2
ATEX Certification	Type II 2G EExd [ia] IIC T4
FM & FMc Certification	I.S. Probe Class 1, Division 2, GP ABCD T3C @ Ta =60C
UL Certification	Pending

CONDUCTIVITY READINGS

The following table details current output readings for the JF-1A-HP sensor with a nominal 0-500 pS/M range representing 4 – 20 mA.

CONDUCTIVITY (Ps/M)	Current (mA)	Voltage * (Volts)
0.0	4.0	1.00
62.5	6.0	1.50
125.0	8.0	2.00
187.5	10.0	2.50
250.0	12.0	3.00
312.5	14.0	3.50
375.0	16.0	4.00
437.5	18.0	4.50
500.0	20.0	5.00

- 250 Ohm Voltage Sensing Resistor Used

7.0 MAINTENANCE

NOTE: There are no user-serviceable components inside the D-2 JF-1A-HP Conductivity Sensor. There are NO Electronic adjustments inside the sensor.

7.1 Calibration Interval

The D-2 JF-1A-HP Conductivity sensor should be calibrated annually. The sensor can be returned to the factory or the procedures found in the calibration section of the user manual performed. The instrument has no internal electrical adjustments that need to be maintained.

7.2 Cleaning

The JF-1A-HP Conductivity Sensor should be cleaned every 6 months of use. Fuel additives or particulate may build up on the sensor, degrading its performance.

7.3 Sensor

The main electronics housing is sealed to the environment. The housing is

purged prior to sealing with dry nitrogen after drying. If the housing is opened the unit must be returned to the factory for re-calibration.

7.4 ZERO TESTS

The best indicator of static operation of the sensor is the reading of the sensor (after appropriate cleaning) in dry air (note excessively humid air may result in higher zero readings). With the sensor cleaned and dry, zero readings should be stable and less than 5 pS/M when read from the serial data port. If the current loop is being monitored zero current should read less than 4.25 mA. If readings are in excess of these values or unstable readings occur, the unit should be returned to the factory for servicing and possible re-calibration.

8.0 ADJUSTMENT

Consult the user manual for adjustment of the JF-1A-HP Sensor.

9.0 SAFE USE AS INTENDED

See Section 2.0 of this manual.

10.0 SPECIAL CONDITIONS OF USE

The JF-1A-HP Sensor is intended for the measure of electrical conductivity of liquids only. It is not intended for any other purpose. There are no special conditions of use for the JF-1A-HP sensor

11.0 2-Wire Temperature Interface

The connection details are shown in Figure 5. The 2-wire temperature interface is connected to JP2 Terminals. These are "snap" out Molex screw terminals which can be removed to assist in wiring. Cabling used should be in compliance with the JF-1A-HP Ex examination certificate. The 2 wire temperature interface is "polarity insensitive". The loop is not powered; power must be supplied by the user.

Figure 5
OPTIONAL TEMPERATURE LOOP
ELECTRICAL CONNECTION DETAIL

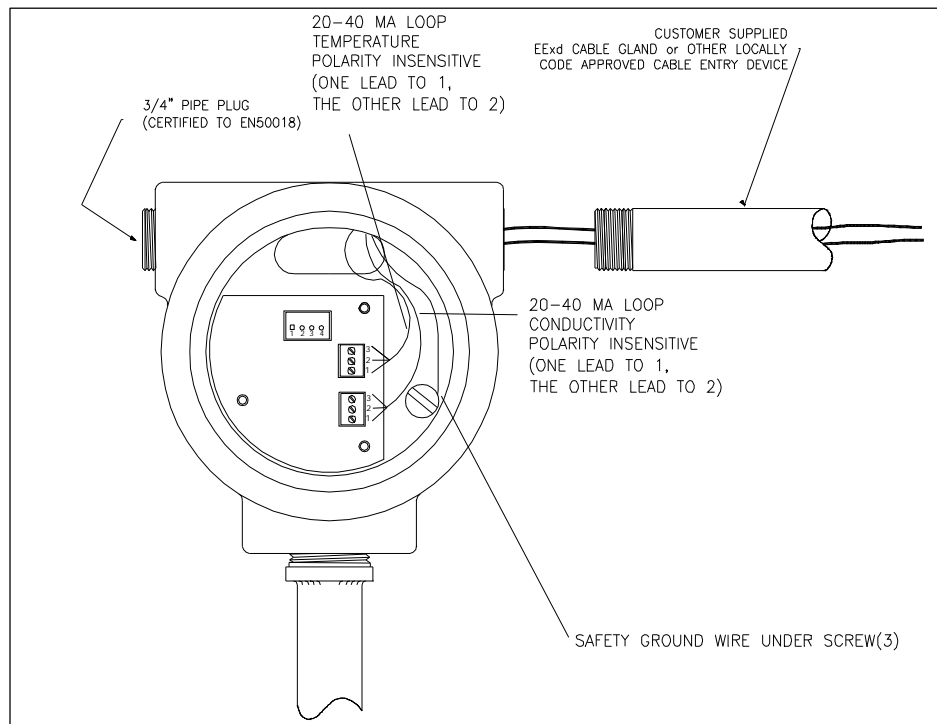

11.1 2-Wire 4-20mA LOOP CONSIDERATIONS



WARNING: 2-Wire Loop Maximum Resistance including wire can not exceed 500 ohms, or internal intrinsic over voltage safety devices in the JF-1A-HP sensor may be activated.



WARNING: For the purpose of intrinsic safety the housing must be tied to earth. Safety Ground wire must be installed under housing ground screw in user wiring compartment. A cable lug shall be used and the conductor shall be mounted so that it is secured against loosening and twisting and that the contact pressure is permanently maintained. Note: the connections to earth located on the terminal blocks can not be used for this earth connection.

The maximum loop power supply voltage, under all conditions, must also prevent the voltage across the sensor loop terminals from exceeding the maximum voltage listed in the specifications section of the manual.

D-2 recommends that a 24 VDC isolated supply be used to power the instrumentation loop. The supply should have high isolation (>500 Mohm), and be single point grounded. The current loop should be wired using shielded twisted pair wire. The shield should also be single point grounded to a solid earth ground.

11.2 4 – 20 mA Temperature Readings

The following table details current output readings for the JF-1A-HP sensor with a nominal -20 to 60 Celsius range representing 4 – 20 mA. (Please consult the factory for alternate range settings of the current output):

Temperature (C)	Current (mA)	Voltage * (Volts)
-20.0	4.0	1.00
0.0	8.0	2.00
20.0	12.0	3.00
40.0	16.0	4.00
60.0	20.0	5.00

- 250 Ohm Voltage Sensing Resistor Used