



D-2 INCORPORATED

High Pressure Jet Fuel 1A Conductivity Sensor JF-1A-HP

OPERATION MANUAL

REVISION - FIRMWARE VERSION 2.7 P/N A443-009

This manual covers the operational aspects of the D-2 JF-1A-HP Conductivity Sensor. D-2 continuously strives to meet the full expectations of our customers and we welcome comments on the structure, content and the ability of this manual to answer your questions regarding our product. If you have any suggestions or comments please contact us at Mail@D-2inc.com. This document is provided with the understanding that future versions of this instrument may have additional commands, and the function of the commands shown in this document may vary from the present operation.

TABLE OF CONTENTS

OPERATION MANUAL	1
P/N A443-009	1
1.0 GENERAL	4
2.0 USAGE	5
3.0 FUNCTION	5
4.0 THEORY OF OPERATION	6
5.0 D-2 JF-1A-HP SENSOR	6
6.0 MECHANICAL INSTALLATION	8
7.0 ELECTRICAL INSTALLATION	9
8.0 TEST PROCEDURE	10
9.0 SENSOR REMOVAL	12
10.0 SPECIFICATIONS	12
11.0 SERIAL DATA INTERFACE	13
12.0 CALIBRATION	18
13.0 COMPENSATED OUTPUT	19

14.0 FILTERED OUTPUT	20
15.0 MAINTENANCE	22
16.0 2-WIRE TEMPERATURE INTERFACE	23
Appendix A: Service & Warranty Policy	25

1.0 GENERAL

The D-2 JF-1A-HP Conductivity Sensor is a reliable instrument for the continuous measurement of electrical conductivity of fuels. The JF-1A-HP Conductivity Sensor incorporates innovative electronics Digital Signal Processing (DSP) techniques to accurately determine the electrical conductivity of fuel products. The instrument will measure fuel electrical conductivities between 0 and 2000 picosiemens/meter (pS/M), although it is optimized and normally used in the 0 to 500 pS/M range. The sensor offers RS-232 data output, or traditional industrial loop compliant 4-20 mA. The 4 -20 mA output can be user programmed to represent a prescribed range of conductivity. User configurations and instrument calibration terms are stored in internal non-volatile memory. The D-2 sensor is continuously internally electronically calibrated. Absolute calibration relies only on the sensor cell constant that is very stable by design. The conductivity sensor has a built-in temperature sensor. Output from the temperature sensor is used to fully compensate the conductivity output from variations due to changes in electrical conductivity as a function of temperature per the ASTM D 2624, Appendix X2 Standard (Appendix A), (See Also Document "[NRC-22648 The Relationship Between Electrical Conductivity and Temperature of Aviation Turbine Fuels Containing Static Dissipater Additives](#)"). The sensor can be provided with an optional 2 (4 – 20mA) wire temperature interface, allowing remote monitoring of fuel temperature.

Figure 1
JF-1A-HP Sensor 2 ½" DIN 100 Flange



2.0 USAGE

Fuel products such as jet aviation and diesel fuels that are transferred at high pumping rates may develop a static electrical charge due to the very low conductance of the fluid. The D-2 JF-1A-HP Conductivity Meter measures the ability of the fuel to dissipate that charge. The conductivity of aviation fuels is purposely increased using additives that reduce the ability of the fuel to store static charge. These additives are normally injected prior to transfer to the load vessel. The D-2 JF-1A-HP Conductivity Sensor has the ability to monitor the electrical conductivity of fuel continuously, allowing its use as a sensing element in an automated additive injection system. The D-2 JF-1A-HP ability to measure with high precision continuously at a high sampling rate (1 hertz) allows for precision control of additive injection. The industrial standard 4-20 mA sensor allows for its use with industry standard PID Controller/Display units combined with additive injector pumps to provide real-time control over addition of conductivity-enhancing additives during the transfer process. The Digital Signal Processing (DSP) full numerical compensation of conductivity for fuel temperature allows the system to be used in facilities independent of a wide range of ambient temperatures. The D-2 JF-1A-HP provides consistent results independent of temperature (when temperature compensation is enabled). Optionally a second 2 Wire (4 – 20 mA) temperature output interface is available.

3.0 FUNCTION

The D-2 JF-1A-HP Conductivity Meter reads conductivity in picosiemens/meter, fuel temperature in ITS-90 degrees C, and fully compensated Conductivity in picosiemens/meter per ASTM D 2624, Appendix X2. These measures are equivalent to CU or Conductivity Units. The sensor can be used in a 2 wire 4-20 mA industrial control loop or in conjunction with a serial input device using RS-232 IEEE Standard ASCII Serial Input Data. Optionally a 2 wire (4-20 mA) temperature interface can be added to allow remote monitoring of fuel temperature.

Figure 2
Major System Components

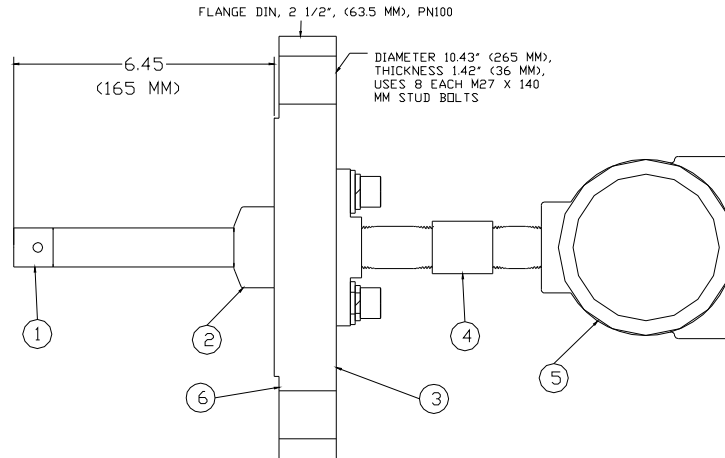

- 1 Sensor Active Tip
- 2 Sensor Isolator
- 3 Mounting Flange
- 4 Safety Sealing Header
- 5 Electronics Housing
- 6 Installation Reference Plane

4.0 THEORY OF OPERATION

The D-2 JF-1A-HP Conductivity Sensor uses a probe consisting of two concentric stainless steel electrodes. When the probe is immersed in fuel, a very low frequency AC voltage is applied to the electrodes. Conduction through the fuel results in an AC electrical current that is amplified, detected, and output as either direct serial ASCII data, or as a standard 4-20 mA industrial current loop. The use of a precision AC voltage overcomes the problem associated with electrode polarization impedance typical of DC type meters, and residual DC charges that may exist in the fuel due to static generation from high-speed pumping. Fluids such as aviation fuels can hold DC charge due to the very low conductance of the fluid. These fuels can have conductivities lower than 5 pS/M in the absence of conductivity-increasing additives.

5.0 D-2 JF-1A-HP SENSOR

Figure 3
D-2 JF-1A-HP On-Line Fuel Sensor Element



The D-2 JF-1A-HP Conductivity Sensor with Flange Mount is shown in Figure 3. The unit is fully contained in a sealed approved housing. The sensor is designed to be fully intrinsically safe for operation in fuel facilities. The back cover allows for direct conduit connection to the meter and offers both 4 - 20 mA output and Serial Data Output Connections. The D-2 JF-1A-HP Conductivity Sensor can be operated as a "two wire" device under ISA 4 - 20 mA loop specification ANSI/ISA-12.12-1994 – Non-incendive Electrical Equipment for Use in Hazardous Locations.

6.0 MECHANICAL INSTALLATION

See Installation and Safe Use Manual for detailed mechanical installation instructions.

6.1 LOCATION

The JF-1A-HP Sensor should be mounted in downstream proximity to the additive injection site. The user MUST insure that additive will be completely mixed at the point at which the fuel is sensed by the JF-1A-HP sensor. An in-line mixer can be used, or more conveniently the injection site can be followed by a pipe "T" or bend to cause turbulent flow mixing of additive. Insufficient mixing will result in poor controller results and erratic average load conductivities.

NOTE: The Sensor should be mounted well away from possible sources of electromagnetic noise, such as large pump motors, AC power Lines, or electrical circuits containing large transient switching currents.

Note: Prior to arc welding in proximity to the JF-1A-HP sensor (closer than 10 meters (30 feet) the sensor should be either removed from the product line or at a minimum disconnected from all electrical connections to the sensor. Welding circulation voltages can exceed protection ratings of the sensitive output circuits located in the JF-1A-HP sensor.

6.2 PIPE CONNECTIONS

See Installation and Safe Use Manual for detailed mechanical pipe connections instructions.

6.3 High Flow Rate Installation

See Installation and Safe Use Manual for detailed mechanical installation in high flow rate lines.

7.0 ELECTRICAL INSTALLATION

See Installation and Safe Use Manual for detailed electrical installation instructions.

7.2 4 – 20 mA CONDUCTIVITY READINGS

The following table details current output readings for the JF-1A-HP sensor with a nominal 0-500 pS/M range representing 4 – 20 mA. (Please consult the factory for alternate range settings of the current output):

CONDUCTIVITY (Ps/M)	Current (mA)	Voltage * (Volts)
0.0	4.0	1.00
62.5	6.0	1.50
125.0	8.0	2.00
187.5	10.0	2.50
250.0	12.0	3.00
312.5	14.0	3.50
375.0	16.0	4.00
437.5	18.0	4.50
500.0	20.0	5.00

- 250 Ohm Voltage Sensing Resistor Used

Conductivity Current Output Setting and Constants:

(See also connection to RS-232 port for serial data commands)

The conductivity value is output on a 4-20 mA loop. This loop is controlled by a D/A who's counts is found using the following formula and constants:

$$\text{Output mA} = \text{DAO} + \text{Conductivity} / \text{DAF} * 2048$$

DAO is set such that the loop outputs exactly 4 mA when the cond=0 command is entered to the unit while in open mode (see serial command section of this manual).

DAF can be set to any value that users needs. Normally DAF is set such that the loop output 20 mA at a conductivity value of 500 pS/m. The user can change the range of the 2-20 mA signal by modifying DAO and DAF as required. As example if DAF is doubled then the range would nearly equal 0 – 1000 pS/M. Please remember that after any adjustment of DAO or DAF to repeat the cond= command to recomputed the 4-20 mA output value. In run mode cond= command is disabled.

7.3 RS-232 CONNECTIONS Considerations (4-Wire)

The RS-232 Interface is fully isolated from the sensor electronics through the use of optical isolators located in the JF-1A-HP/ATEX sensor.

7.4 RS-232 Wiring Considerations (4-Wire)

Data cable for the RS-232 should be low capacitance data cable. Lengths in excess of 20 meters may result data degradation of the RS-232 signals.

7.5 Power Input (4-Wire)

Power input to the 4-Wire power connections should be clean filtered DC voltage in the range of 7 – 35 VDC. Current consumption is approximately 10 mA.

8.0 TEST PROCEDURE

8.1 POWER INSTRUMENT

Connect Instrument to suitable power supply (See Section 7.0 for detailed electrical connections). Attach D-2 Test Cable P/N A440-043 to the 4-Wire connector located on the user connection interface. See Figure 7.

8.2 CHECK ZERO READING

With the sensor removed from the Load line rinse the sensor in "Clean" Isopropyl Alcohol and blow dry using "dry" compressed air. Note that this step should be repeated until all signs of fuel residual have been removed from the

sensor.

Note: Isopropyl Alcohol is highly conductive and any residual traces inside the sensor between the two electrodes will overage the instrument. To flush the Isopropyl Alcohol a reagent grade toluene can be used as an after rinse and allowed to air dry. Note that if the Isopropyl Alcohol is well blown off with dry compressed air no residuals will be left, eliminating the need to use the more exotic Toluene.

When JFWIN is reporting low values (less than 5 pS/M) the user can be satisfied that the sensor is clean. When ready to zero, press the "Zero Calibration" data button in the JFWIN Menu. The program will report data being taken and completion when done. Readings on the screen should report less than 2 pS/M and should be stable. The Green Zero OK Light will light when complete.

8.3 SCALE CHECK SENSOR

Place the sensor in a fuel with additive that is near the full-scale range of interest. We suggest a value "higher" than the range over which the sensor is going to be operated. For example, if the user intends to measure conductivity in the 0 – 500 pS/M range a good value to calibrate the sensor with is 750 – 1000 pS/M. This reduces uncertainty over the range of interest. The value of the standard can be measured using an Emcee hand-held meter or other suitable and industry-accepted standardization device. Verify the serial data from the JF-1A-HP reads the same +/-10%.

9.0 SENSOR REMOVAL

See Installation and Safe Use Manual for detailed mechanical removal instructions.

10.0 SPECIFICATIONS

The electrical parameters are factory calibrated to 1% of reading. However, due to fuel measurement characteristics, the repeatability and reproducibility limits are as follows:

Table 2
SENSOR SPECIFICATIONS

SENSORS:

Parameter	Conductivity	Temperature
Range	0 – 500 pS/M	-5 – 50 C
Accuracy *	+/- 2 pS/M (+/- 2%) of Reading	+/- 0.5 C
Resolution	0.1 pS/M	0.1 C
Sensor Type	Coaxial Electrode	Platinum RTD
Calibration	Internal Zero & Scale	NIST ITS-90

* This is at temperatures +/- 10° C of 20° C for the compensated output data only.

Table 3
SYSTEM SPECIFICATIONS

SYSTEM:

ELEMENT	SPECIFICATION
Flow Range	0 – 7.0 M/s Max
Environmental	-10 to 60 C Operation -40 to 80 C Storage
Power 2-Wire Input	24 VDC Minimum 38 VDC Maximum
Power 4-Wire Input	7 VDC Minimum 38 VDC Maximum
Pressure	100 BAR Maximum
Certification Housing	FM, CSA, UL, CENELEC
Certification Sensor	ATEX
Usage	Class 2, Division 2
ATEX Certification	EExd [ia] IIC T4/5/6
FM Certification	Pending
UL Certification	Pending

11.0 SERIAL DATA INTERFACE

The D-2 JF-1A-HP has a comprehensive serial interface. The instrument contains no internal electrical adjustments. All instrument calibration constants and configurations are stored in internal non-volatile memory. The unit also has programmable output span range for the 4-20 mA output, allowing the user to customize the unit to a specific application. The factory default range is for the 4 - 20 mA range to represent 0 - 500 pS/M conductivity range. The unit also has programmable temperature compensation constants, for observing alternate thermal compensation for the specific additive effect on the conductivity of the treated fuel. Lastly, the user has the ability to set averaging of data that is applied to both serial output data and to 4-20 mA data.

Note: *D-2 Windows 98/NT compatible program JFWIN can be provided. This program provides a complete PC interface to the D-2*

JF-1A-HP Conductivity Sensor, providing calibration, data collection, real-time display, and data logging for this sensor system. Consult the factory.

11.1 RUN MODE

When powered the unit commences operation in the "RUN MODE." The unit sends the following sign on ASCII message at 9600 Baud, 8 Data Bits, No Parity and 1 Stop bit:

(Note: Orator Text Used For All Instrument Outputs)

```
D-2 Incorporated
Fuel Cell JF1
1.6
  COND,  TEMP,  COMP COND
(ps/m)   (C)   (ps/m-C)
```

The last two lines are headers for the data output columns. To collect data the user need only send an ASCII Carriage Return (Hex 0A) <CR> or ASCII Line Feed (Hex 0D) <LF>. The unit will respond with a single line of data:

```
13.0,    15.4,    23.8<CF><LF>
```

Where: 13.0 = Conductivity Measured
 15.4 = Temperature of Fuel in Celsius
 23.8 = Compensated Conductivity

11.2 CONTINUOUS DATA

To have the unit send data continuously without polling, the user can send the "SC" Set Continuous Command. The unit will commence sending data at the data rate and current averaging rate. If the averaging is set to 1 sample then the data rate is approximately 2.0 hertz. If the averaging is set to 2 samples then the 2 samples are averaged together and the data rate is 1 hertz. Boxcar averaging is used, i.e., $\text{Data Average} = 1/N \text{ New Data} + N-1/N \text{ Old Data}$. To stop continuous data the unit will only accept one command, which is the capital "S" Stop Command followed by a carriage return or line feed.

Note: The Stop Command is the only case sensitive command!

11.3 OPEN MODE

In OPEN MODE the unit stops collecting data and awaits user instructions such as calibration constants, or averaging settings, etc. The OPEN MODE can be attained by sending the "***O" command. The unit after entering open mode will send "OPEN MODE" when polled using a carriage return or line feed. From open mode the user can view all constants using the "RCAL" command. The RCAL Command will return the following:

***O

```

Open Mode
RCAL
1314
ZERO=55.000000
FS=1900.000000
BT=67.759354
MT=-9.510620E-05
TREF=20.100000
MC=1.280000E-02
N=1.000000
W=30
NREF=1.000000
DAO=375
DAF=500.000000
    
```

In the Table Below the definition of each of these constants is given:

Table 4
OPERATIONAL CONSTANTS

Constant	Definition
1314	Unit Serial Number
ZERO	The value assigned to the zero reference reading, used to set $Y=MX+B$ for the conductivity channel
FS	The value assigned to the Full Scale reference reading, used to set $Y=MX+B$ for the conductivity channel
BT	The Temperature Channel Offset Value
MT	The Temperature Channel Slope Value

TREF	The Temperature Reference for Conductivity Compensation
MC	The Temperature Coefficient of Jet Fuel with Additive Per ASTM
N	The Number of Samples of Conductivity Box Car Averaged See Section 13.0
NREF	The number of Reference Channels Averaged
DAO	The 4-20 mA output offset counts to trim current to 4.0 mA at Zero Conductivity
DAF	The 4-20 mA full Scale in pS/M for an load current of 20 mA Total
W	Anti Spike Filter Maximum Scan-Scan Change in pS/M
TRL	Low end temperature equal to 4 mA output from the temperature current loop.

Any constant can be read individually by entering the reference name followed by a <CR>. Any constant can be set by entering the reference followed by an equal's sign and then the new value to be entered. All constants can be stored in non-volatile memory using the ***E command. Note, cycling power after changing constants and before storing them in non-volatile memory using the ***E command will result in the unit reverting to the original values stored.

To return to run mode, issue the ***R command or cycle power.

Current Loop Output Testing

The JF-1A-HP, while in OPEN MODE, can temporarily output a current equal to a given conductivity reading for system testing. To output a current equal to a given conductivity, as example 250 pS/M, while in OPEN MODE issue the command COND=250. This command will configure the output to draw current equal to a reading of 250 pS/M, or on a 0 – 500 pS/M configured sensor 12 milliamps. Readings and output currents for various range configured units is given in the table below. (Note, the JF-1A-HP is normally configured for a 0 – 500 pS/M range equating to a 4 – 20 mA current range.)

Conductivity	0-500 pS/M *	0-1000 pS/M	0-2000 pS/M
	CURRENT mA	CURRENT mA	CURRENT mA
0	4	4	4
125	8	6	5
250	12	8	6
375	16	10	7
500	20	12	8
750	-	16	10
1000	-	20	12
1250	-	-	14
1500	-	-	16
1750	-	-	18
2000	-	-	20

11.4 CALIBRATION MODE

In CALIBRATION OPEN MODE the unit collects data and outputs all raw data and processes measurements allowing the JFWIN Program to calculate operational constants. To enter the CALIBRATION MODE the "***C" command sent from the OPEN MODE (See Open Mode Above). After entering CALIBRATION MODE the unit will send the following frame of data when polled using a carriage return or line feed. The SET CONTINUOUS "SC" command also operates in Calibration Mode

***C

-9433, 639606, -8351, 491805, 2.2, 21.0, 2.1

Where:

-9433 = Counts Electronic Zero Reference

639606 = Counts Electronic Full Scale Reference

-8351 = Counts Conductivity Circuit Reference
491805 = Counts Temperature Circuit
2.2 = Calculated Conductivity pS/M
21.0 = Calculated Temperature Celsius
2.1 = Calculated Compensated Conductivity pS/M

(Note that the numbers above are examples only; actual values obtained will vary)

12.0 CALIBRATION

If either AIR Reading of ZERO larger than +/- 2pS/M is observed or the user suspects that the unit is not reading correctly the following steps should be completed.

12.1 SENSOR REMOVAL

Consult Safe Use Manual for Sensor Removal Instructions.

12.2 POWER SENSOR

Using D-2 Test Cable P/N A440-043 Connect the sensor to a suitable power supply, and the serial connector to COM 1 of the PC. Load and run the D-2 program JFWIN.

12.2 CLEAN SENSOR

Clean the sensor in "Clean" Isopropyl Alcohol and blow dry using "dry" compressed air. Note that this step should be repeated until all signs of fuel residual have been removed from the sensor.

Note: Isopropyl Alcohol is highly conductive and any residual traces inside the sensor between the two electrodes will overage the instrument. To flush the Isopropyl Alcohol a reagent grade toluene can be used as an after rinse and allowed to air dry. Note that if the Isopropyl Alcohol is well blown off with dry compressed air no residuals will be left, eliminating the need to use the more exotic Toluene.

When JFWIN is reporting low values (less than 5 pS/M), the user can be

satisfied that the sensor is clean. When ready to zero, press the "Zero Calibration" data button in the JFWIN Menu. The program will report data being taken and completion when done. Readings on the screen should report less than 2 pS/M and be stable. The Green Zero OK Light will light when complete.

12.3 SET SENSOR SCALE

Place the sensor in a fuel with additive that is near the full-scale range of interest. We suggest a value "higher" than the range over which the sensor is going to be operated. For example, if the user intends to measure conductivity in the 0 – 500 pS/M range a good value to calibrate the sensor with is 750 – 1000 pS/M. This reduces uncertainty over the range of interest. The value of the standard can be measured using an Emcee hand-held meter or other suitable and industry-accepted standardization device. On the JFWIN screen depress the "SCALE CALIBRATE" menu button, and enter the sample standard value when requested. When the program cycle is complete the "Scale Complete Light" will light and values reported should correspond to the standard sample value entered in the program.

13.0 COMPENSATED OUTPUT

The D-2 JF-1A-HP Conductivity Sensor outputs conductivity compensated for temperature differences in the fuel from the temperature at which the sensor was physically calibrated. The compensation is based on a numerical algorithm:

$$C_i = 10^{(MC * (T_{REF} - t) + \text{Log}(C))}$$

Where:

C_i = Compensated Conductivity Reading

C = Measured Conductivity Reading

MC = Compensation Constant (Nominally 0.028 for fuels treated with Stadis 450)

T_{REF} = Reference Temperature (the temperature at which the sensor was initially calibrated)

T = Measured Temperature

Log = Log Base 10

This formula is based on the ASTM D 2624, Appendix X2 Standard See also

NRC-22648 The Relationship Between Electrical Conductivity and Temperature of AVIATION Turbine Fuels Containing Static Dissipater Additives”

Table 5 gives the change in conductivity as a function of temperature for several values of initial conductivity at 22 C.

Table 5
Conductivity (pS/M) as a Function of Temperature (Aviation Fuel Treated with Stadis 450)

Conductivity	50	150	250	350	450
Temperature					
-2	25	74	123	173	222
2	28	83	139	194	250
6	31	94	156	218	281
10	35	105	176	246	316
14	39	118	197	276	355
18	44	133	222	311	400
22	50	150	250	350	450
26	56	169	281	394	506
30	63	190	316	443	570
34	71	214	356	499	641
38	80	240	401	561	721
42	90	270	451	631	811
46	101	304	507	710	913
50	114	342	571	799	1027

The D-2 JF-1A-HP Current Output is base on *Compensated Conductivity*. To prevent compensation the user must set "MC" to zero (See Serial Command Section of this manual).

14.0 FILTERED OUTPUT

Boxcar (low pass filter) Average:

The D-2 JF-1A-HP Conductivity Sensor has a user specified filtered output. The output is box car averaged. The number of box cars can be set from 1 (no filtering) to 10 (maximum filtering). The box car filter has the numerical equivalent of a low pass filter. Mathematically the form is:

Filtered Output = $1/n * \text{new reading} + n-1/n * \text{old reading}$

In the table below 63% and 90% response times are given for each box card setting. See Section 10.0 for setting the box car number constant n.

Box Car Average N	63% Response Seconds	90% Response Seconds
1	1	1
2	3	7
3 *	6	11
4	7	17
5	9	21
6	11	26
7	13	30
8	15	36
9	17	40
10	19	44

- N= 3 is Factory Default

Window (Data De-Spike filter):

Window Filter “W”. This Window filter can be used with or without N set. Essentially the window filter limits the rate at which the JF-1A-HP sensor output can change from scan to scan. W has units pS/cm/scan, and can be set from 1 – 999. W is an effective tool to reduce data output spikes in installations where sudden physical changes of the system may cause data spikes. In essence if the raw conductivity value changes greater more than the current setting of W, the output change is limited to W. If N is also set then the output change is limited to $W * 1/N$.

The mathematical formula for Window Filter has the form:

Test = Raw old – Raw new

If Test > W then Limit Change to W

De-spiked Output = $1/n * W + n-1/n * \text{old reading}$

15.0 MAINTENANCE

NOTE: There are no user-serviceable components inside the D-2 JF-1A-HP Conductivity Sensor. There are NO Electronic adjustments inside the sensor.

15.1 Calibration Interval

The D-2 JF-1A-HP Conductivity sensor should be calibrated annually. The sensor can be returned to the factory or the procedures found in the calibration section of this manual performed. The instrument has no internal electrical adjustments that need to be maintained.

15.2 Cleaning

The JF-1A-HP Conductivity Sensor should be cleaned every 6 months of use. Fuel additives or particulate may build up on the sensor, degrading its performance. The sensor can be cleaned using the same procedure found for checking the instrument Zero in the previous sections.

15.3 Sensor

The main electronics housing is sealed to the environment. The housing is purged prior to sealing with dry nitrogen after drying. This ensures that moisture or condensation do not develop inside the electronics compartment that would degrade the ability of the sensor to measure the very low conductivities typical of aviation fuels. If the housing is opened the unit must be returned to the factory for re-calibration.

15.4 ZERO TESTS

The best indicator of static operation of the sensor is the reading of the sensor (after appropriate cleaning) in dry air (note excessively humid air may result in higher zero readings). With the sensor cleaned and dry, zero readings should be stable and less than 5 pS/M when read from the serial data port. If the current loop is being monitored zero current should read less than 4.25 mA. If readings are in excess of these values or unstable readings occur, the unit should be returned to the factory for servicing and possible re-calibration.

16.0 2 Wire Temperature Interface

Consult Safe Use Manual For Installations of Temperature Current Loop.

16.1 2-Wire 4-20mA LOOP CONSIDERATIONS

The power supply for the temperature current loop must be fully isolated from the conductivity loop supply that also powers the instrument.

14.2 4 – 20 mA Temperature Readings

The following table details current output readings for the JF-1A-HP sensor with a nominal -20 to 60 Celsius range representing 4 – 20 mA. (Please consult the factory for alternate range settings of the current output):

Temperature (C)	Current (mA)	Voltage * (Volts)
-20.0	4.0	1.00
0.0	8.0	2.00
10.0	10.0	2.50
20.0	12.0	3.00
30.0	14.0	3.50
40.0	16.0	4.00
50.0	18.0	4.50
60.0	20.0	5.00

- 250 Ohm Voltage Sensing Resistor Used

Temperature Current Output Setting and Constants:
(See also connection to RS-232 port for serial data commands)

The temperature value is output on a 4-20 mA loop. This loop is controlled by a D/A who's counts is found using the following formula and constants:

$$\text{Output mA} = \text{TDAO} + (\text{Temperature} - \text{TRL}) / \text{TDAF} * 2048$$

TDAO is set such that the loop outputs exactly 4 mA when the temp= is set equal to the TRL value is entered to the unit while in open mode (see serial command section of this manual).

TDAF can be set to any value that users needs. Normally TDAF is set such that the loop output 20 mA at a temperature value of 60 C. The user can change the range of the 2-20 mA signal by modifying TDAO, TRL, and TDAF as required. As example if the low end of the range is to change to -10C from the factory default of -20C, TRL can be set to -10, set temp to -10 using the Temp=-10 command, adjust TDAO until exactly 4 mA is output (remember to resend temp=1- after each adjustment of TDAO is made. The 20 mA output can then be adjusted using the TDAF constant. In run mode temp= command is disabled.

APPENDIX A:

LIMITED WARRANTY

One year from date of shipment, D-2 Incorporated, guarantees its products to be free of defects in materials and workmanship. In the event a product malfunctions during this period, the company obligation is limited to repair of the defective item at our factory, or the defective item may be replaced at our option. Instruments found defective should be returned to the factory prepaid and carefully packed, as customer will be responsible for freight damage. D-2 will pay return shipping on any warranty repairs.

Repairs or replacements under warranty will be at no cost to the customer for parts, labor, or return shipment from our factory to the customer. This warranty is void if in our opinion the instrument has been damaged by accident, mishandled, altered or repaired by the customer where such treatment has affected its performance or reliability. In the event of such abuse by the customer, all costs for repairs plus freight costs will be borne by the customer. All equipment supplied by D-2 that is designed for use under hydrostatic loading has been certified by actual pressure testing prior to shipment.

The customer will be charged a diagnostic fee plus all shipping costs if an instrument is returned for warranty repair and no defect is found by the factory. Incidental or consequential damages or costs incurred as a result of product malfunction are not the responsibility of D-2 Incorporated.

Equipment not manufactured by D-2 Incorporated, is supported only to the extent of the original manufacturer's original warranties. All OEM sensors which utilize electrodes (oxygen cartridges, pH, ORP, etc.) is warranted at the time of shipment, and shall perform upon initial installation within stated specifications. If the product proves to be defective within the OEM's warranty we will replace the product or defective part with a similar model, product or part, but only to the extent that the OEM will warrant.

All returned products must be accompanied by a Returned Material Authorization (RMA) number issued by D-2 Incorporated. Shipments will not be accepted without the RMA number. An RMA number can be obtained by calling

Customer Service Department at 508-564-7640 or by emailing Mail@D-2inc.com.

The following information should accompany any instrument being returned to the factory:

Return Authorization Number
Model/Serial Number
Brief Description of the Problem
Customer Contact/Telephone Number

CALIBRATION SERVICE POLICY

A calibration only service is available for JF-1A-HP Conductivity Sensors.

The service is limited to instruments requiring only calibration and minor adjustment. Instruments that are not operating properly and require repair or replacement parts will not be covered. If repair is necessary the customer will be contacted and apprised of the additional cost. The customer will be charged the standard repair cost, which includes repair and calibration. In the event that the customer does not approve repair, the unit will be returned in "as received" condition and the teardown and inspection charge will be invoked.

The customer will be required to obtain a return authorization number from Customer Service at D-2 Incorporated prior to the return of the instrument. This number should be displayed on the outside of the container, preferably on the shipping label, and included on the shipping documentation sent with the instrument.

If possible, the following information should accompany the instrument:

Return Authorization Number
Model/Serial Number
Customer Contact/Telephone Number